

**SENIER**



# Stick Packing Machine

# Stick Packing Machine

- Feature ■
- Function ■
- Advantage ■
- Application ■
- Specification ■

## Stick Packing Machine Feature

- ◆ Famous brand PLC control system, large touch screen, convenient to operate
- ◆ Advanced design, high precision and fast speed
- ◆ No film alarm, saving materials and no wasting film
- ◆ Photoelectric tracking system for precise bag length and position of film
- ◆ Machine case is made of 304 stainless steel, which is more good for food



- ◆ Famous brands of PLC control system and electrical components, 7inch' touch screen for high accuracy and adjusting
- ◆ Servo motor pulling film system, guaranteeing high quality and stable running
- ◆ Intelligent sensor positioning, automatic measurement and calculation of bag length
- ◆ Complete automatic alarm protection function to minimize the loss
- ◆ The machine uses the temperature controller to control the temperature it will automatically alarms and stops the machine when the temperature is too high or too low, reducing the loss of spare parts

## Stick Packing Machine Function

- ◆ Automatically measuring volume, making bags, filling, sealing, cutting, printing the lot number and cutting easy tearing notches, finished product conveying. Applicable for the powder powder, such as coffee powder, medical powder, milk powder, flour, bean powder etc.



our superior

**Stick**

**Packing Machine** PRODUCT

## Stick Packing Machine Advantage

- ◆ Import cutter mode to ensure uniform bag appearance, smooth edges and no burrs
- ◆ The horizontal sealing part use double cylinders to ensure synchronous completion and pressure equalization so that the sealing pattern of each row of bags is beautiful and neat
- ◆ Compatible with various filling systems



## Stick Packing Machine Application

Suitable to package granule product, such as :

- ◆ Salt
- ◆ Washing Powder
- ◆ Spice etc

It can be used in these industries:

- ◆ Parmaceutical industry
- ◆ Health product industry
- ◆ Food & Cosmetic industry

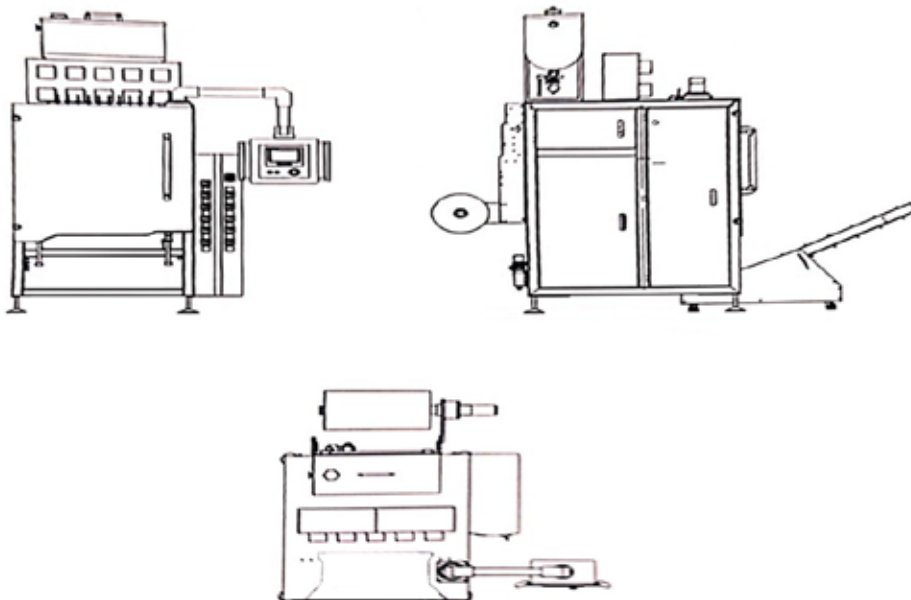

## Stick Packing Machine Specification

### Multi Lane Liquid Stick Packing Machine

| Model                | SSP280BY   | SSP560BY                |
|----------------------|--|-------------------------|
| Lane number          | 4~6 Lane   | 8~12 Lane               |
| Measuring Method     | 1. Piston pump; 2. Peristaltic pump                      |                         |
| Capacity             | Max.35 cycle/min   |                         |
| Bag size             | L:50-180mm;W:17-30mm                                     | L:50--180mm;W:17-30mm   |
| Film width&thickness | Max.280mm;0.07--0.10mm                                   | Max.560mm;0.07--0.10mm  |
| Sealing type         | Back sealing/Stick bag                                   | Back sealing/Stick bag  |
| Cutting type         | 1.Straight cutting ; 2.Zig zag cutting ; 3.Round cutting |                         |
| Air&Power            | 0.8Mpa 0.8m3/min; 3.5kw                                  | 0.8Mpa 0.8m3/min; 5.5kw |
| DIM&WT               | 1385*918*2005mm; 350kg                                   | 1685*1300*2005mm; 550kg |



## Stick Packing Machine Specification

### Multi Lane Powder Stick Packing Machine

| Model                | SSP280BS   | SSP560BS                |
|----------------------|--|-------------------------|
| Lane number          | 4~6 Lane   | 8~12 Lane               |
| Filling Method       | 1. Volumetric cup; 2. weigher                            |                         |
| Capacity             | Max.35 cycle/min   |                         |
| Bag size             | L:50-180mm;W:17-30mm                                     | L:50--180mm;W:17-30mm   |
| Film width&thickness | Max.280mm;0.07--0.10mm                                   | Max.560mm;0.07--0.10mm  |
| Sealing type         | Back sealing/Stick bag                                   | Back sealing/Stick bag  |
| Cutting type         | 1.Straight cutting ; 2.Zig zag cutting ; 3.Round cutting |                         |
| Air&Power            | 0.8Mpa 0.8m3/min; 3.5kw                                  | 0.8Mpa 0.8m3/min; 5.5kw |
| DIM&WT               | 1385*918*2005mm; 350kg                                   | 1685*1300*2005mm; 550kg |





## Stick Packing Machine Specification

### Multi Lane Granule Stick Packing Machine

| Model                | SSP280BS   | SSP560BS                |
|----------------------|--|-------------------------|
| Lane number          | 4~6 Lane   | 8~12 Lane               |
| Filling Method       | 1.Volumetric cup; 2.Weigher                              |                         |
| Capacity             | Max.35 cycle/min   |                         |
| Bag size             | L:50-180mm;W:17-30mm                                     | L:50--180mm;W:17-30mm   |
| Film width&thickness | Max.280mm;0.07--0.10mm                                   | Max.560mm;0.07--0.10mm  |
| Sealing type         | Back sealing/Stick bag                                   | Back sealing/Stick bag  |
| Cutting type         | 1.Straight cutting ; 2.Zig zag cutting ; 3.Round cutting |                         |
| Air&Power            | 0.8Mpa 0.8m3/min; 3.5kw                                  | 0.8Mpa 0.8m3/min; 5.5kw |
| Dimension&weight     | 1385*918*2005mm; 350kg                                   | 1685*1300*2005mm; 550kg |

